

Switch Mode Power Supply

S8VK-G (15/30/60/120/240/480-W Models)

Reliable and Easy Operation
Resistant in tough environments
Easy and fast installation
The most compact size on the market

- Universal input for worldwide applications:
100 to 240 VAC (85 to 264 VAC)
- DC input available: 90 to 350 VDC
- Possible 2 phases input usage.
- Wide operation temperature range: -40 to 70 °C
- Power Boost function at 120%
- Safety standards:
UL508/60950-1, CSA C22.2 No. 107.1/60950-1
EN50178 (= VDE0160), EN60950-1 (= VDE0805).
Lloyd's standards*, EN60204-1 PELV
Safety of Power Transformers: EN61558-2-16
- 15-W,30-W, and 60-W models conform to
UL Class 2 output Standards
- EMS: EN 61204-3
- EMI: EN61204-3 Class B

* Scheduled to obtain certification in June, 2013.



Refer to *Safety Precautions for All Power Supplies* and *Safety Precautions* on page .

S8VK-G

Model Number Structure

Model Number Legend

Note: Not all combinations are possible. Refer to *List of Models in Ordering Information*, below.

S8VK-
 1 2 3

1. Input voltage types

G: Single phase

2. Power Ratings

015: 15 W
 030: 30 W
 060: 60 W
 120: 120 W
 240: 240 W
 480: 480 W

3. Output voltage

05: 5 V
 12: 12 V
 24: 24 V
 48: 48 V

Ordering Information

Note: For details on normal stock models, contact your nearest OMRON representative.

Power ratings	Input voltage	Output Voltage	Output current	Boost Current	Model number
15 W	Single phase 100 to 240 VAC 90 to 350 VDC	5 V	3 A	3.6 A	S8VK-G01505
		12 V	1.2 A	1.44 A	S8VK-G01512
		24 V	0.65 A	0.78 A	S8VK-G01524
30 W		5 V	5 A	6 A	S8VK-G03005
		12 V	2.5 A	3 A	S8VK-G03012
		24 V	1.3 A	1.56 A	S8VK-G03024
60 W		12 V	4.5 A	5.4 A	S8VK-G06012
		24 V	2.5 A	3 A	S8VK-G06024
120 W		24 V	5 A	6 A	S8VK-G12024
240 W		24 V	10 A	12 A	S8VK-G24024
		48 V	5 A	6 A	S8VK-G24048
480 W		24 V	20 A	24 A	S8VK-G48024
	48 V	10 A	12 A	S8VK-G48048	

Specifications

Ratings, Characteristics, and Functions

Item	Power ratings		15 W			30 W		
	Output voltage		5 V	12 V	24 V	5 V	12 V	24 V
Efficiency (Typical)	230 VAC input		77%		80%	79%	82%	86%
Input	Voltage *1		100 to 240 VAC, 90 to 350 VDC (allowable range: 85 to 264 VAC) *6					
	Frequency *1		50/60 Hz (47 to 450 Hz)					
	Current (Typical)	115 VAC input	0.32 A	0.3 A	0.31 A	0.5 A	0.57 A	0.58 A
		230 VAC input	0.2 A	0.21 A	0.2 A	0.32 A	0.37 A	0.36 A
	Power factor (Typical)	230 VAC input	0.42			0.43	0.42	0.43
	Harmonic current emissions		Conforms to EN61000-3-2					
	Leakage current (Typical)	115 VAC input	0.14 mA			0.13 mA		
		230 VAC input	0.25 mA			0.24 mA		
	Inrush current (Typical) *2	115 VAC input	16 A					
230 VAC input		32 A						
Output	Voltage adjustment range *3		-10% to 15% (with V.ADJ) (guaranteed)					
	Ripple *4	at 20 MHz (Typical)	60 mV	50 mV	30 mV	30 mV	30 mV	30 mV
	Input variation influence		0.5% max. (at 85 to 264 VAC input, 100% load)					
	Load variation influence (Rated Input voltage)		3.0% max. (5 V), 2.0% max. (12 V), 1.5% max. (24 V), at 0% to 100% load					
	Temperature variation influence		0.05%/°C max.					
	Start up time (Typical) *2	115 VAC input	530 ms	520 ms	580 ms	550 ms	550 ms	600 ms
		230 VAC input	330 ms	400 ms	400 ms	430 ms	490 ms	480 ms
	Hold time (Typical) *2	115 VAC input	28 ms	29 ms	32 ms	33 ms	36 ms	23 ms
		230 VAC input	134 ms	138 ms	134 ms	177 ms	170 ms	154 ms
Additional functions	Overload protection *2		121% to 160% of rated load current (130% typ value)					
	Overvoltage protection *2		Yes *5					
	Power Boost		120% of rated current (Refer to Engineering Data)					
	Parallel operation		Yes (Refer to Engineering Data)					
	Series operation		Possible for up to two Power Supplies (with external diode)					
Others	Ambient operating temperature		-40 to 70°C (Refer to Engineering Data)					
	Storage temperature		-40 to 85°C					
	Ambient operating humidity		0% to 95% (Storage humidity: 0% to 95%)					
	Dielectric strength (detection current: 20 mA)		3.0 kVAC for 1 min. (between all inputs and outputs) 2.0 kVAC for 1 min. (between all inputs and PE terminal) 1.0 kVAC for 1 min. (between all outputs and PE terminal)					
	Insulation resistance		100 MΩ min. (between all outputs and all inputs/ PE terminals) at 500 VDC					
	Vibration resistance		10 to 55 Hz, 0.375-mm single amplitude for 2 h each in X, Y, and Z directions 10 to 150 Hz, 0.35-mm single amplitude (5 G max.) for 80 min. each in X, Y, and Z directions					
	Shock resistance		150 m/s ² , 3 times each in ±X, ±Y, and ±Z directions					
	Output indicator		Yes (color: green), lighting from 80% to 90% or more of rated voltage					
	EMI	Conducted Emission	Conforms to EN61204-3 EN55011 Class B and based on FCC Class A					
		Radiated Emission	Conforms to EN61204-3 EN55011 Class B					
	EMS		Conforms to EN61204-3 high severity levels					
	Approved Standards		UL Listed: UL508 (Listing, Class2 Output: Per UL1310) UL UR: UL60950-1 (Recognition) cUL: CSA C22.2 No.107.1 (Class2 Output: Per CSA C22.2 No.223) cUR: CSA C22.2 No.60950-1 EN/VDE: EN50178 (=VDE0160), EN60950-1 (=VDE0805) Lloyd's standards *7					
	Fulfilled Standards		SELV (EN60950-1/EN50178/UL60950-1), PELV (EN60204-1, EN50178), Safety of Power Transformers (EN61558-2-16) EN50274 for Terminal parts					
	Degree of protection		IP20 by EN / IEC60529					
	SEMI		F47-0706 (200 to 240 VAC)					
Weight		150 g			195 g			

*1. Do not use an inverter output for the Power Supply. Inverters with an output frequency of 50/60 Hz are available, but the rise in the internal temperature of the Power Supply may result in ignition or burning.

*2. For a cold start at 25°C. Refer to *Engineering Data* on page 11 for details.

*3. If the output voltage adjuster (V. ADJ) is turned, the voltage will increase by more than +15% of the voltage adjustment range. When adjusting the output voltage, confirm the actual output voltage from the Power Supply and be sure that the load is not damaged.

*4. A characteristic when the ambient operating temperature is between -25 to 70°C.

*5. To reset the protection, turn OFF the input power for three minutes or longer and then turn it back ON.

*6. 90 to 350 VDC's UL standards are scheduled to obtain certification in June, 2013.

*7. Scheduled to obtain certification in June, 2013.

S8VK-G

Item	Power ratings		60 W		120 W
	Output voltage		12 V	24 V	24 V
Efficiency (Typical)	230 VAC input		85%	88%	89%
Input	Voltage *1		100 to 240 VAC, 90 to 350 VDC (allowable range: 85 to 264 VAC) *6		
	Frequency *1		50/60 Hz (47 to 450 Hz)		50/60 Hz (47 to 63 Hz)
	Current (Typical)	115 VAC input	1.0 A	1.1 A	1.3 A
		230 VAC input	0.6 A	0.7 A	
	Power factor (Typical)	230 VAC input	0.46	0.45	0.94
	Harmonic current emissions		Conforms to EN61000-3-2		
	Leakage current (Typical)	115 VAC input	0.16 mA		0.24 mA
		230 VAC input	0.30 mA		0.38 mA
Inrush current (Typical) *2	115 VAC input	16 A			
	230 VAC input	32 A			
Output	Voltage adjustment range *3		-10% to 15% (with V.ADJ) (guaranteed)		
	Ripple *4	at 20 MHz (Typical)	150 mV	50 mV	150 mV
	Input variation influence		0.5% max. (at 85 to 264 VAC input, 100% load)		
	Load variation Influence (Rated Input voltage)		2.0% max. (12 V), 1.5% max. (24 V), at 0% to 100% load		
	Temperature variation influence		0.05%/°C max.		
	Start up time (Typical) *2	115 VAC input	570 ms	650 ms	790 ms
		230 VAC input	430 ms	500 ms	750 ms
	Hold time (Typical) *2	115 VAC input	26 ms	25 ms	42 ms
230 VAC input		139 ms	129 ms	42 ms	
Additional functions	Overload protection *2		121% to 160% of rated load current, (130% typ value)		121% to 160% of rated load current, (125% typ value)
	Overvoltage protection *2		Yes *5		
	Power Boost		120% of rated current (Refer to Engineering Data)		
	Parallel operation		Yes (Refer to Engineering Data)		
	Series operation		Possible for up to two Power Supplies (with external diode)		
Others	Ambient operating temperature		-40 to 70°C (Refer to Engineering Data)		
	Storage temperature		-40 to 85°C		
	Ambient operating humidity		0% to 95% (Storage humidity: 0% to 95%)		
	Dielectric strength (detection current: 20 mA)		3.0 kVAC for 1 min. (between all inputs and outputs) 2.0 kVAC for 1 min. (between all inputs and PE terminal) 1.0 kVAC for 1 min. (between all outputs and PE terminal)		
	Insulation resistance		100 MΩ min. (between all outputs and all inputs/ PE terminals) at 500 VDC		
	Vibration resistance		10 to 55 Hz, 0.375-mm single amplitude for 2 h each in X, Y, and Z directions 10 to 150 Hz, 0.35-mm single amplitude (5 G max.) for 80 min. each in X, Y, and Z directions		
	Shock resistance		150 m/s ² , 3 times each in ±X, ±Y, and ±Z directions		
	Output indicator		Yes (color: green), lighting from 80% to 90% or more of rated voltage		
	EMI	Conducted Emission	Conforms to EN61204-3 EN55011 Class B and based on FCC Class A		
		Radiated Emission	Conforms to EN61204-3 EN55011 Class B		
	EMS		Conforms to EN61204-3 high severity levels		
	Approved Standards		UL Listed: UL508 (Listing, For 60 W only Class2 Output: Per UL1310) UL UR: UL60950-1 (Recognition) cUL: CSA C22.2 No.107.1 (For 60 W only Class2 Output: Per CSA C22.2 No.223) cUR: CSA C22.2 No.60950-1 EN/VDE: EN50178 (=VDE0160), EN60950-1 (=VDE0805) Lloyd's standards *7		
	Fulfilled Standards		SELV (EN60950-1/EN50178/UL60950-1), PELV(EN60204-1, EN50178), Safety of Power Transformers (EN61558-2-16) EN50274 for Terminal parts		
	Degree of protection		IP20 by EN / IEC60529		
	SEMI		F47-0706 (200 to 240 VAC)		
Weight		260 g		620 g	

*1. Do not use an inverter output for the Power Supply. Inverters with an output frequency of 50/60 Hz are available, but the rise in the internal temperature of the Power Supply may result in ignition or burning.

*2. For a cold start at 25°C. Refer to *Engineering Data* on page 11 for details.

*3. If the output voltage adjuster (V. ADJ) is turned, the voltage will increase by more than +15% of the voltage adjustment range. When adjusting the output voltage, confirm the actual output voltage from the Power Supply and be sure that the load is not damaged.

*4. A characteristic when the ambient operating temperature is between -25 to 70°C.

*5. To reset the protection, turn OFF the input power for three minutes or longer and then turn it back ON.

*6. 90 to 350 VDC's UL standards are scheduled to obtain certification in June, 2013.

*7. Scheduled to obtain certification in June, 2013.

Item	Power ratings		240 W		480 W	
	Output voltage		24 V	48 V	24 V	48 V
Efficiency (Typical)	230 VAC input		92%		93%	
Input	Voltage *1		100 to 240 VAC, 90 to 350 VDC (allowable range: 85 to 264 VAC) *6			
	Frequency *1		50/60 Hz (47 to 63 Hz)			
	Current (Typical)	115 VAC input	2.4 A		4.7 A	
		230 VAC input	1.3 A		2.3 A	
	Power factor (Typical)	230 VAC input	0.9		0.97	
	Harmonic current emissions		Conforms to EN61000-3-2			
	Leakage current (Typical)	115 VAC input	0.23 mA		0.3 mA	
		230 VAC input	0.33 mA		0.49 mA	
Inrush current (Typical) *2	115 VAC input	16 A				
	230 VAC input	32 A				
Output	Voltage adjustment range *3		-10% to 15% (with V.ADJ) (guaranteed)			
	Ripple *4	at 20 MHz (Typical)	180 mV	350 mV	230 mV	470 mV
	Input variation influence		0.5% max. (at 85 to 264 VAC input, 100% load)			
	Load variation Influence (Rated Input voltage)		1.5% max. (24 V, 48 V), at 0% to 100% load			
	Temperature variation influence		0.05%/°C max.			
	Start up time (Typical) *2	115 VAC input	250 ms	290 ms	380 ms	
		230 VAC input	250 ms	290 ms	260 ms	
	Hold time (Typical) *2	115 VAC input	44 ms	43 ms	40 ms	
230 VAC input		44 ms		50 ms		
Additional functions	Overload protection *2		121% to 160% of rated load current (130% typ value)			
	Overvoltage protection *2		Yes *5			
	Power Boost		120% of rated current (Refer to Engineering Data)			
	Parallel operation		Yes (Refer to Engineering Data)			
	Series operation		Possible for up to two Power Supplies (with external diode)			
Others	Ambient operating temperature		-40 to 70°C (Refer to Engineering Data)			
	Storage temperature		-40 to 85°C			
	Ambient operating humidity		0% to 95% (Storage humidity: 0% to 95%)			
	Dielectric strength (detection current: 20 mA)		3.0 kVAC for 1 min. (between all inputs and outputs) 2.0 kVAC for 1 min. (between all inputs and PE terminal) 1.0 kVAC for 1 min. (between all outputs and PE terminal)			
	Insulation resistance		100 MΩ min. (between all outputs and all inputs/ PE terminals) at 500 VDC			
	Vibration resistance		10 to 55 Hz, 0.375-mm single amplitude for 2 h each in X, Y, and Z directions			
	Shock resistance		150 m/s ² , 3 times each in ±X, ±Y, and ±Z directions			
	Output indicator		Yes (color: green), lighting from 80% to 90% or more of rated voltage			
	EMI	Conducted Emission	Conforms to EN61204-3 EN55011 Class B and based on FCC Class A			
		Radiated Emission	Conforms to EN61204-3 EN55011 Class B			
	EMS		Conforms to EN61204-3 high severity levels			
	Approved Standards		UL Listed: UL508 (Listing) UL UR: UL60950-1 (Recognition) cUL: CSA C22.2 No.107.1 cUR: CSA C22.2 No.60950-1 EN/VDE: EN50178 (=VDE0160), EN60950-1 (=VDE0805) Lloyd's standards *7			
	Fulfilled Standards		SELV (EN60950-1/EN50178/UL60950-1), PELV(EN60204-1, EN50178), Safety of Power Transformers (EN61558-2-16) EN50274 for Terminal parts			
	Degree of protection		IP20 by EN / IEC60529			
	SEMI		F47-0706 (200 to 240 VAC)			
	Weight		900 g		1,500 g	

*1. Do not use an inverter output for the Power Supply. Inverters with an output frequency of 50/60 Hz are available, but the rise in the internal temperature of the Power Supply may result in ignition or burning.

*2. For a cold start at 25°C. Refer to *Engineering Data* on page 11 for details.

*3. If the output voltage adjuster (V. ADJ) is turned, the voltage will increase by more than +15% of the voltage adjustment range. When adjusting the output voltage, confirm the actual output voltage from the Power Supply and be sure that the load is not damaged.

*4. A characteristic when the ambient operating temperature is between -25 to 70°C.

*5. To reset the protection, turn OFF the input power for three minutes or longer and then turn it back ON.

*6. 90 to 350 VDC's UL standards are scheduled to obtain certification in June, 2013.

*7. Scheduled to obtain certification in June, 2013.

S8VK-G

Connections

Block Diagrams

S8VK-G015□□ (15 W)

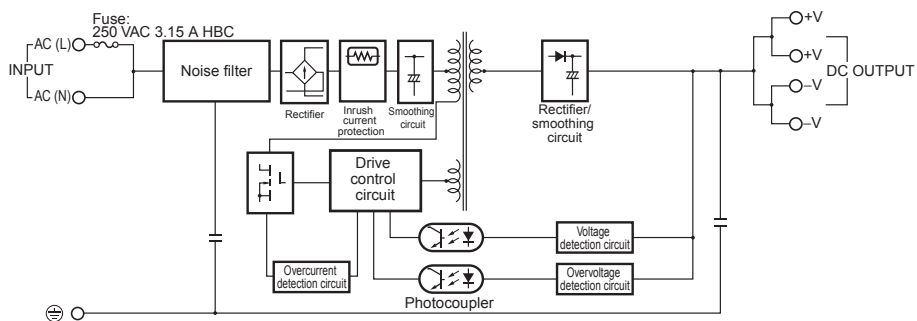

S8VK-G030□□ (30 W)

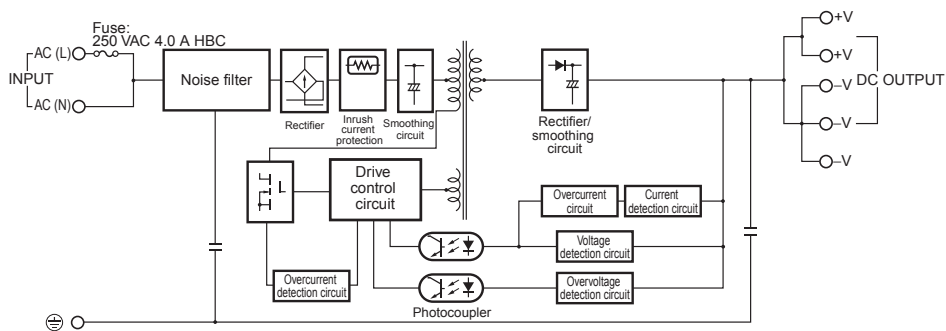

S8VK-G060□□ (60 W)

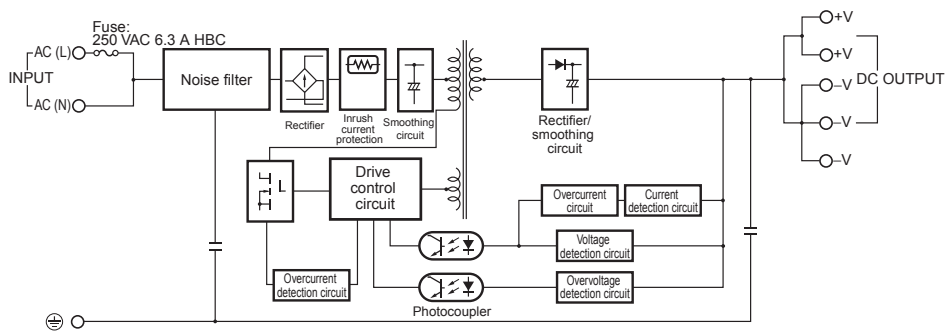

S8VK-G12024 (120 W)

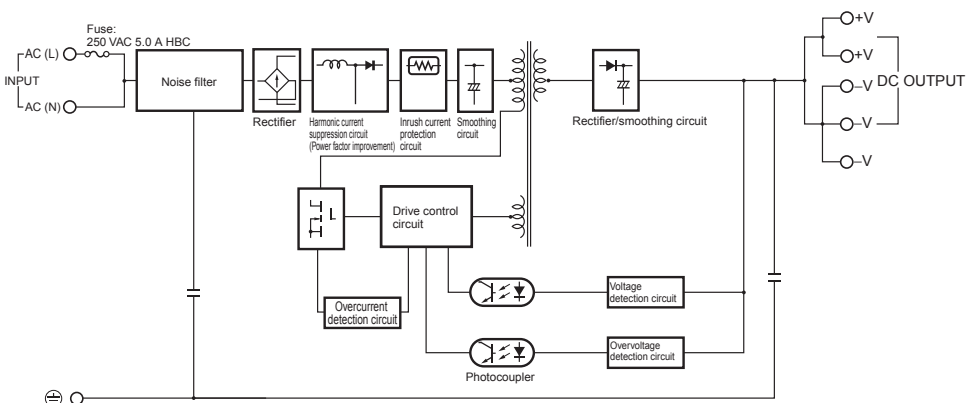

S8VK-G240 (240 W)

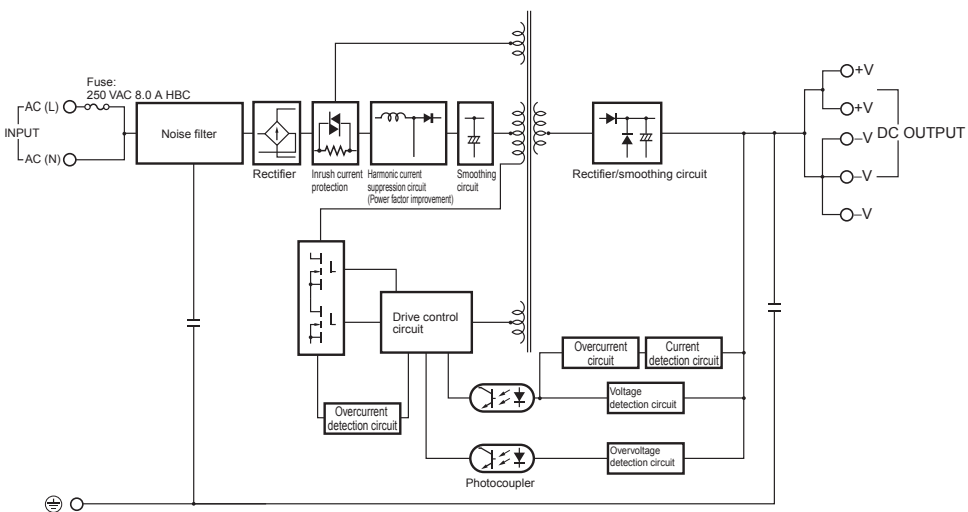

S8VK-G480 (480 W)

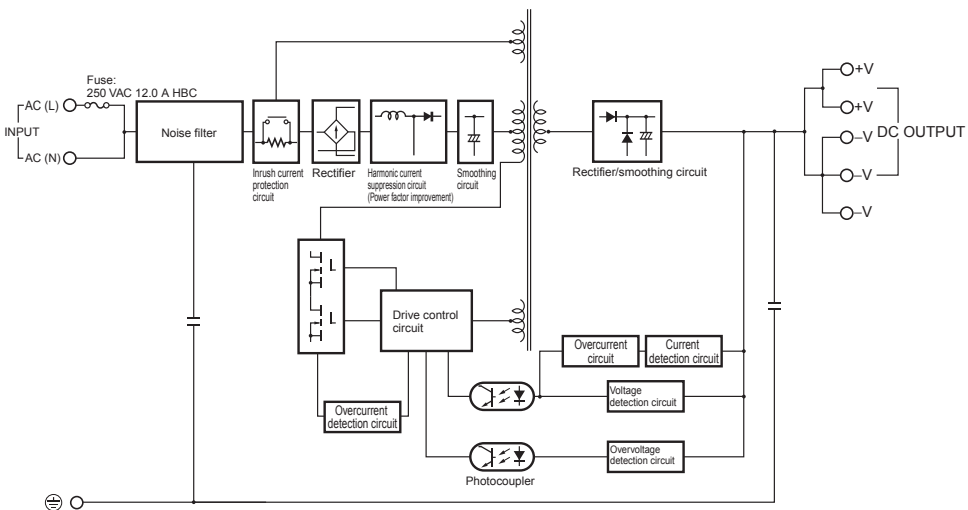

S8VK-G

Construction and Nomenclature

Nomenclature

15-W Models

S8VK-G015□□

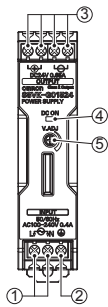

30-W Models

S8VK-G030□□

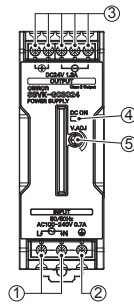

60-W Models

S8VK-G060□□

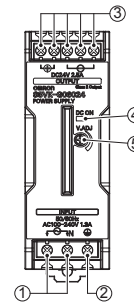

120-W Models

S8VK-G12024

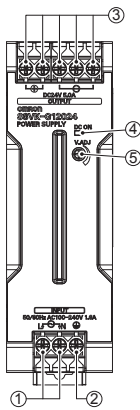

240-W Models

S8VK-G240□□

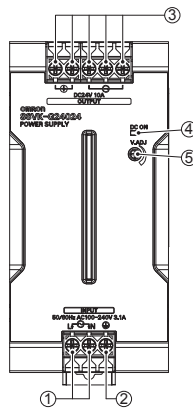

480-W Models

S8VK-G480□□

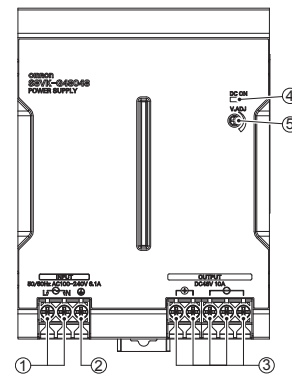

No.	Name	Function
1	Input terminals (L), (N)	Connect the input lines to these terminals. *1
2	Protective Earth terminal (PE)	Connect the ground line to this terminal. *2
3	DC Output terminals (-V), (+V)	Connect the load lines to these terminals.
4	Output indicator (DC ON: Green)	Lights while a direct current (DC) output is ON.
5	Output voltage adjuster (V.ADJ)	Use to adjust the voltage.

*1. The fuse is located on the (L) side. It is not user-replaceable. For a DC input, connect the positive voltage to the L terminal.

*2. This is the protective earth terminal specified in the safety standards. Always ground this terminal.

Engineering Data

Derating Curve

15, 30, 240 W (S8VK-G015□□, S8VK-G030□□, S8VK-G240□□)

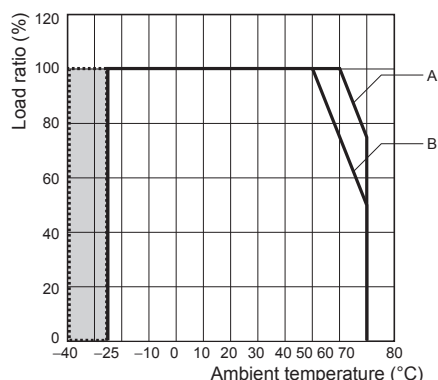

- Note:**
- At less than 90 VAC, the derating is 2.5%/V
 - For a DC power input, reduce the load given in the above derating curve by multiplying the following coefficients.
 S8VK-G015□□: 1.0
 S8VK-G030□□: 0.9
 S8VK-G240□□: 0.8
 - See “-40°C Operation Guarantee Condition”
- A.** Standard mounting
 60°C and over: the derating is 2.5%/°C
- B.** Face-up mounting / Side mounting (15W only)
 50°C and over: the derating is 2.5%/°C

120 W (S8VK-G12024)

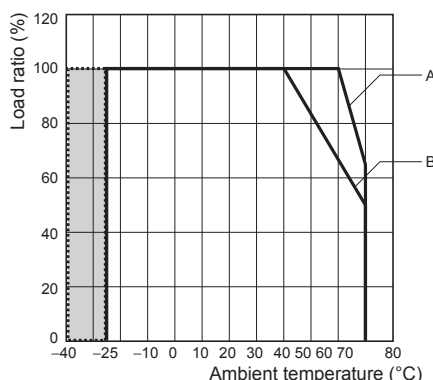

- Note:**
- At less than 90 VAC, the derating is 2.5%/V
 - For a DC power input, reduce the load given in the above derating curve by multiplying the following coefficients.
 S8VK-G12024: 0.9
 - See “-40°C Operation Guarantee Condition”
- A.** Standard mounting
 60°C and over: the derating is 3.5%/°C
- B.** Face-up mounting
 40°C and over: the derating is 1.67%/°C

60 W (S8VK-G060□□)

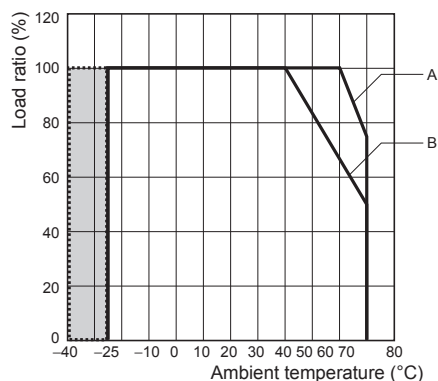

- Note:**
- At less than 90 VAC, the derating is 2.5%/V
 - For a DC power input, reduce the load given in the above derating curve by multiplying the following coefficients.
 S8VK-G060□□: 0.9
 - See “-40°C Operation Guarantee Condition”
- A.** Standard mounting
 60°C and over: the derating is 2.5%/°C
- B.** Face-up mounting
 40°C and over: the derating is 1.67%/°C

480 W (S8VK-G480□□)

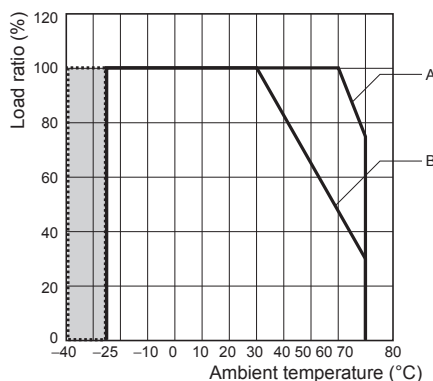

- Note:**
- At less than 90 VAC, the derating is 2.5%/V
 - For a DC power input, reduce the load given in the above derating curve by multiplying the following coefficients.
 S8VK-G480□□: 0.8
 - See “-40°C Operation Guarantee Condition”
- A.** Standard mounting
 60°C and over: the derating is 2.5%/°C
- B.** Face-up mounting
 30°C and over: the derating is 1.75%/°C

-40°C Operation Guarantee Condition

The unit can start up and operate normally at -40°C, but the following criteria will be inferior to the values of datasheet. Please consider these influences.

		15 W 5 V	15 W 12 V	15 W 24 V	30 W 5 V	30 W 12 V	30 W 24 V	60 W 12 V	60 W 24 V	120 W 24 V	240 W 24 V	240 W 48 V	480 W 24 V	480 W 48 V
Ripple (Typ.)	230 VAC input	280 mV	170 mV	100 mV	110 mV	330 mV	180 mV	200 mV	420 mV	440 mV	840 mV	1220 mV	460 mV	580 mV
Ripple (Max.)	230 VAC input	830 mV	450 mV	220 mV	240 mV	630 mV	290 mV	480 mV	430 mV	450 mV	1030 mV	1320 mV	670 mV	870 mV
Start up time (Typ.)	230 VAC input	420 ms	440 ms	490 ms	410 ms	440 ms	480 ms	420 ms	490 ms	760 ms	230 ms	280 ms	260 ms	260 ms
Hold time (Typ.)	230 VAC input	88 ms	110 ms	109 ms	137 ms	112 ms	114 ms	124 ms	118 ms	20 ms	35 ms	37 ms	39 ms	41 ms

Mounting

(A) Standard (Vertical) mounting

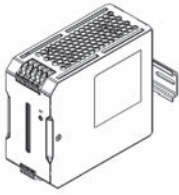

(B) Face-up mounting



(C) Side mounting only for 15 W

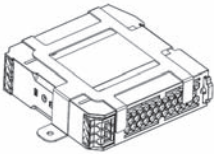

Overload Protection

The load and the power supply are automatically protected from overcurrent damage by this function.

Overload protection is activated if the output current rises above 121% of the rated current.

When the output current returns within the rated range overload protection is automatically cleared.

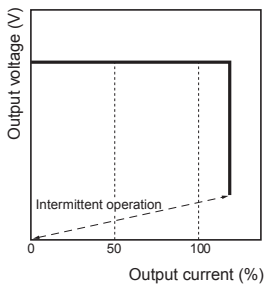

The values shown in the above diagrams are for reference only.

- Note:**
- Internal parts may occasionally deteriorate or be damaged if a short-circuited or overcurrent state continues during operation.
 - Internal parts may possibly deteriorate or be damaged if the Power Supply is used for applications with frequent inrush current or overloading at the load end. Do not use the Power Supply for such applications.

Power Boost Function

For All Models

Power Boost is a function that can output the temporary repeated boost current larger than the rated current. However, it should meet the following four Boost current conditions.

- Time that the boost current flows: t_1
- The maximum value of the boost current: I_p
- The average output current: I_{ave}
- The time ratio of the boost current flow: Duty

Note: Boost current conditions

$$t_1 \leq 10 \text{ s}$$

$$I_p \leq \text{Rated boost current}$$

$$I_{ave} \leq \text{Rated current}$$

$$\text{Duty} = \frac{t_1}{t_1 + t_2} \times 100 [\%] \leq 30\%$$

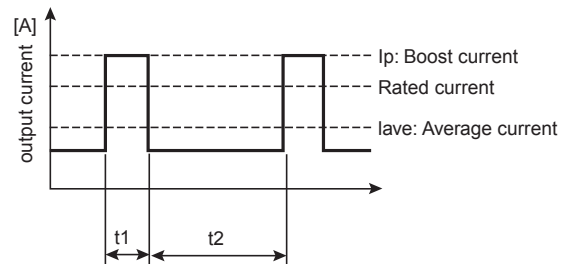

- Do not allow the boost current to continue for more than 10 seconds. Also, do not let the duty cycle exceed the boost current conditions. These conditions may damage the Power supply.
- Ensure that the average current of one cycle of the boost current does not exceed the rated output current. This may damage the Power Supply.
- Lessen the load of the boost load current by adjusting the ambient temperature and the mounting direction.

Overvoltage Protection

Consider the possibility of an overvoltage and design the system so that the load will not be subjected to an excessive voltage even if the feedback circuit in the Power Supply fails. If an excessive voltage that is approximately 130% of the rated voltage or more is output, the output voltage is shut OFF. Reset the input power by turning it OFF for at least three minutes and then turning it back ON again.

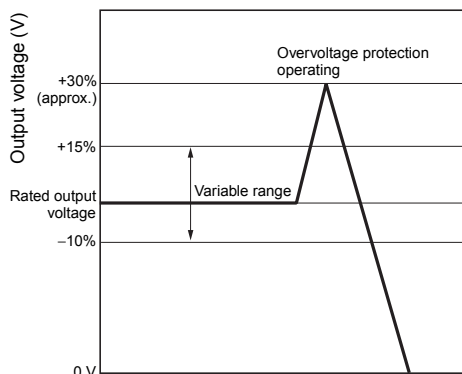

The values shown in the above diagram is for reference only.

Note: Do not turn ON the power again until the cause of the overvoltage has been removed.

Inrush Current, Startup Time, Output Hold Time

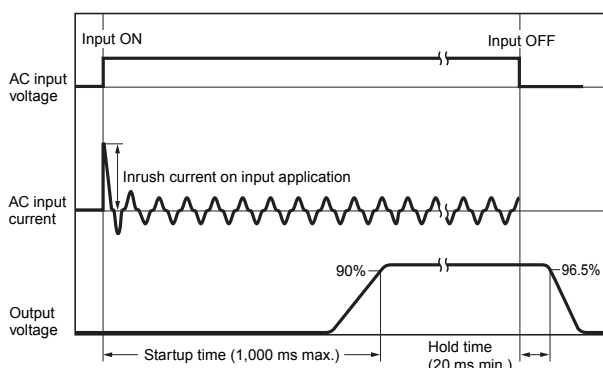

Note: Twice the input current or above will flow during the parallel operation or redundant system. Therefore, check the fusing characteristics of fuses and operating characteristics of breakers making sure that the external fuses will not burn out and the circuit breakers will not be activated by the inrush current.

Two phases application for Single phase models For All Single phase Models, S8VK-G

Basically OMRON single phase power supply can be used on two-phases of a 3-phase-system when some of conditions satisfy like below.

1. The supplying voltage is below the maximum rated input. OMRON Power supply allows the input voltage equivalent or less than 240 VAC+10%. Please confirm the input voltage between two lines if the input voltage satisfies this condition before connecting.
2. The external protector is needed on N input line to secure a safety. N line has no protection of a fuse internally. An appropriate fuse or circuit breaker should be connected on N input line like the following.

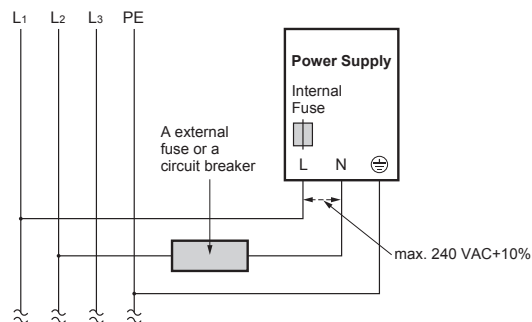

Parallel Operation

The parallel operation of S8VK-G is possible to increase the output power.

However please consider the following notes when the parallel operation must be done.

1. The range of ambient temperature for Parallel operation is -25 to 40°C
2. Up to two of the same model can be connected in parallel.
3. Adjust the output voltage difference of each Power Supply to 50 mV or less, using the output voltage adjuster (V. ADJ).
4. There is no current balancing function for S8VK-G. A high output voltage unit may work at overcurrent state and in this situation, a life of a Power Supply will be extremely short. After adjusting the output voltage, confirm the output current of the two Power Supplies balances.
5. Using the parallel operation will not satisfy UL1310 Class2 output.
6. For Parallel Operation, to balance the current of the each unit, the length and thickness of each wire connected to the load and each unit must be same as much as possible.
7. For Parallel Operation with units 120 W or less, connect diodes or S8VK-R to the outputs of each unit if sudden load variation influence occurs in the ambient operation environment.

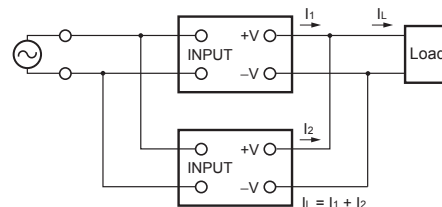

Reference Value

	Value
Reliability (MTBF)	Single phase model
	15 W: 600,000 hrs
	30 W: 580,000 hrs
	60 W: 590,000 hrs
	120 W: 450,000 hrs
	240 W: 360,000 hrs
	480 W: 230,000 hrs
Definition	MTBF stands for Mean Time Between Failures, which is calculated according to the probability of accidental device failures, and indicates reliability of devices. Therefore, it does not necessarily represent a life of the product.
Life expectancy	10 yrs. Min.
Definition	The life expectancy indicates average operating hours under the ambient temperature of 40°C and a load rate of 50%. Normally this is determined by the life expectancy of the built-in aluminum electrolytic capacitor.

S8VK-G

Dimensions

(Unit: mm)

S8VK-G015□□ (15 W)

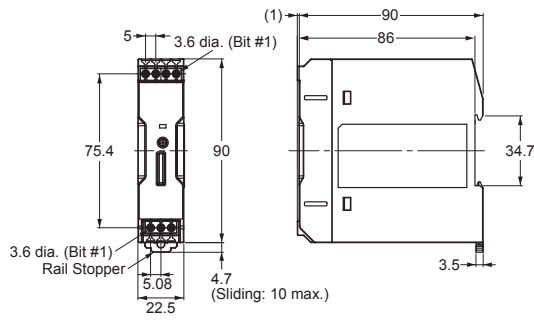

S8VK-G030□□ (30 W)

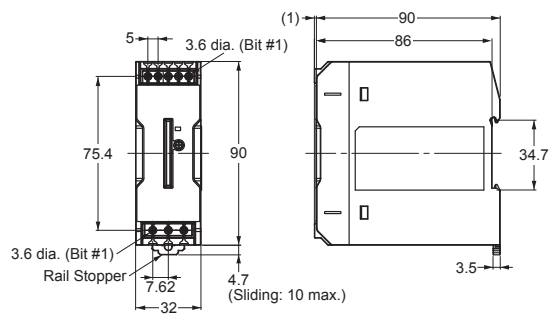

S8VK-G060□□ (60 W)

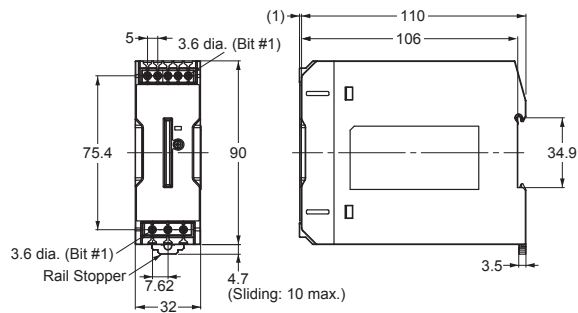

S8VK-G12024 (120 W)

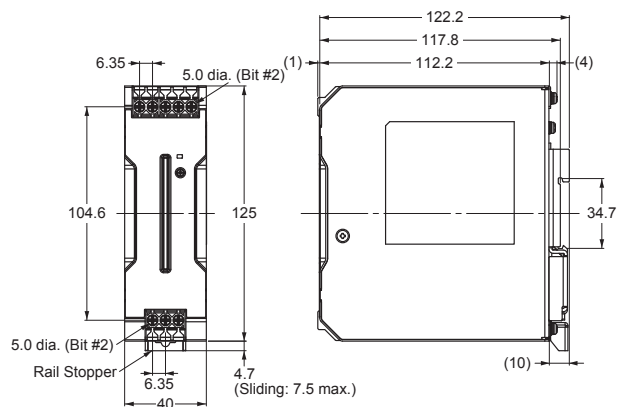

S8VK-G240□□ (240 W)

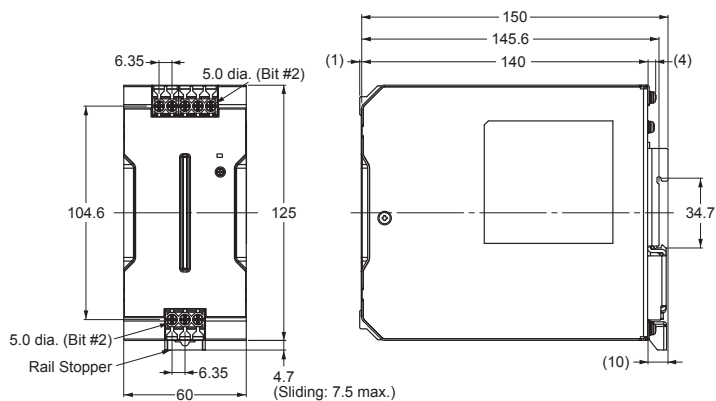

S8VK-G480□□ (480 W)

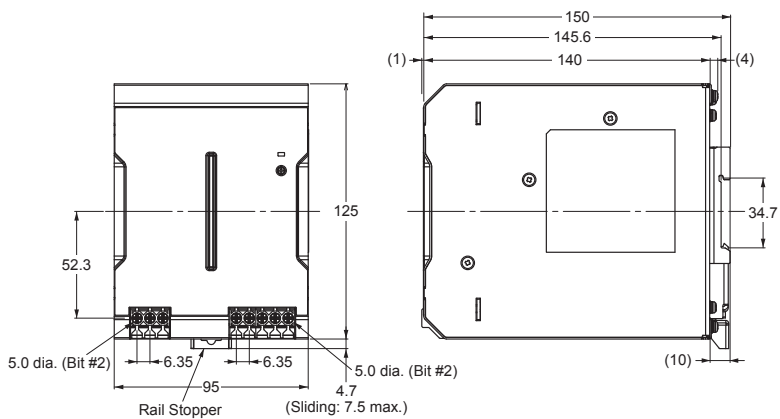

DIN Rail (Order Separately)

Note: All units are in millimeters unless otherwise indicated.

Mounting Rail (Material: Aluminum)

PFP-100N

PFP-50N

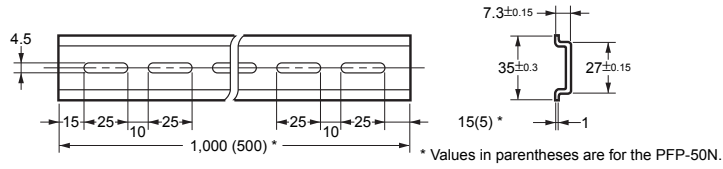
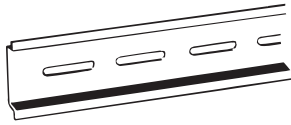

Mounting Rail (Material: Aluminum)

PFP-100N2

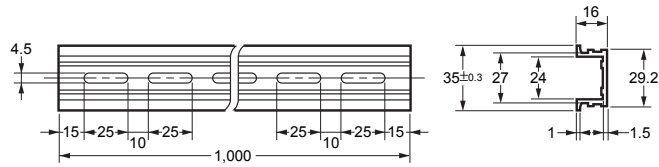
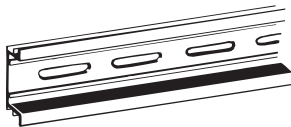

End Plate

PFP-M

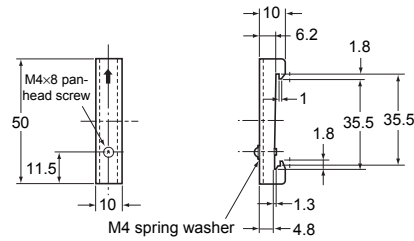
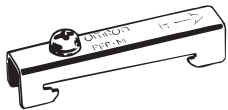

Note: If there is a possibility that the Unit will be subject to vibration or shock, use a steel DIN Rail. Otherwise, metallic filings may result from aluminum abrasion.

Mounting Brackets

Name	Model
Front-mounting bracket (for 15, 30 and 60 W models)	S82Y-VS10F
Front-mounting bracket (for 120, 240 and 480 W models)	S82Y-VK10F
Side-mounting bracket (for 15 W models)	S82Y-VK15P
Side-mounting bracket (for 30 and 60 W models)	S82Y-VS10S
Side-mounting bracket (for 120 W models)	S82Y-VK10S
Side-mounting bracket (for 240 W models)	S82Y-VK20S

Type	Model	Dimensions	Appearance
Front-mounting bracket (For 15, 30 and 60 W models)	S82Y-VS10F		
Front-mounting bracket (for 120, 240 and 480 W models)	S82Y-VK10F		<p>(For 120 W types) (For 240 W types)</p>
Side-mounting bracket (For 15 W Models)	S82Y-VK15P		<p>Right-side mounting</p>

S8VK-G





Type	Model	Dimensions	Appearance
Side-mounting bracket (For 30 and 60 W models)	S82Y-VS10S	<p style="text-align: center;">$t = 2.0$</p>	Left-side mounting Right-side mounting
Side-mounting bracket (For 120 W models)	S82Y-VK10S	<p style="text-align: center;">$t = 2.0$</p>	Left-side mounting Right-side mounting
Side-mounting bracket (For 240 W models)	S82Y-VK20S	<p style="text-align: center;">$t = 2.0$</p>	Left-side mounting Right-side mounting

Safety Precautions

Warning Indications

 CAUTION	Indicates a potentially hazardous situation which, if not avoided, may result in minor or moderate injury or in property damage.
Precautions for Safe Use	Supplementary comments on what to do or avoid doing, to use the product safely.
Precautions for Correct Use	Supplementary comments on what to do or avoid doing, to prevent failure to operate, malfunction or undesirable effect on product performance.

Meaning of Product Safety Symbols

	Used to warn of the risk of electric shock under specific conditions.
	Used to warn of the risk of minor injury caused by high temperatures.
	Used for general mandatory action precautions for which there is no specified symbol.
	Use to indicate prohibition when there is a risk of minor injury from electrical shock or other source if the product is disassembled.

CAUTION

Minor electric shock, fire, or Product failure may occasionally occur. Do not disassemble, modify, or repair the Product or touch the interior of the Product.



Minor burns may occasionally occur. Do not touch the Product while power is being supplied or immediately after power is turned OFF.



Fire may occasionally occur. Tighten terminal screws to the specified torque (0.5 to 0.6 N·m).



Minor injury due to electric shock may occasionally occur. Do not touch the terminals while power is being supplied. Always close the terminal cover after wiring.



Minor electric shock, fire, or Product failure may occasionally occur. Do not allow any pieces of metal or conductors or any clippings or cuttings resulting from installation work to enter the Product.



Precautions for Safe Use

Wiring

- Connect the ground completely. A protective earthing terminal stipulated in safety standards is used. Electric shock or malfunction may occur if the ground is not connected completely.
- Minor fire may possibly occur. Ensure that input and output terminals are wired correctly.
- Do not apply more than 75-N force to the terminal block when tightening it.
- Be sure to remove the sheet covering the Product for machining before power-ON so that it does not interfere with heat dissipation.
- Use the following material for the wires to be connected to the S8VK-G to prevent smoking or ignition caused by abnormal loads.

Terminals and Wiring

Model	INPUT		OUTPUT		PE	
	American Wire Gauge	Solid Wire /Stranded Wire	American Wire Gauge	Solid Wire /Stranded Wire	American Wire Gauge	Solid Wire /Stranded Wire
S8VK-G01505	AWG24 to 12	0.25 to 4 mm ² /0.25 to 2.5 mm ²	AWG20 to 12	0.5 to 4 mm ² /0.5 to 2.5 mm ²	AWG14 or thicker	2.5 mm ² or thicker /2.5 mm ² or thicker
S8VK-G01512			AWG22 to 12	0.35 to 4 mm ² /0.35 to 2.5 mm ²		
S8VK-G01524			AWG24 to 12	0.25 to 4 mm ² /0.25 to 2.5 mm ²		
S8VK-G03005	AWG24 to 12	0.25 to 4 mm ² /0.25 to 2.5 mm ²	AWG18 to 12	0.75 to 4 mm ² /0.75 to 2.5 mm ²		
S8VK-G03012			AWG20 to 12	0.5 to 4 mm ² /0.5 to 2.5 mm ²		
S8VK-G03024			AWG22 to 12	0.35 to 4 mm ² /0.35 to 2.5 mm ²		
S8VK-G06012	AWG22 to 12	0.35 to 4 mm ² /0.35 to 2.5 mm ²	AWG18 to 12	0.75 to 4 mm ² /0.75 to 2.5 mm ²		
S8VK-G06024			AWG20 to 12	0.5 to 4 mm ² /0.5 to 2.5 mm ²		
S8VK-G12024	AWG22 to 10	0.35 to 6 mm ² /0.35 to 4 mm ²	AWG18 to 10	0.75 to 6 mm ² /0.75 to 4 mm ²		
S8VK-G24024	AWG20 to 10	0.5 to 6 mm ² /0.5 to 4 mm ²	AWG14 to 10	2.5 to 6 mm ² /2.5 to 4 mm ²		
S8VK-G24048			AWG18 to 10	0.75 to 6 mm ² /0.75 to 4 mm ²		
S8VK-G48024	AWG16 to 10	1.5 to 6 mm ² /1.5 to 4 mm ²	AWG12 to 10	4 to 6 mm ² /4 mm ²		
S8VK-G48048			AWG14 to 10	2.5 to 6 mm ² /2.5 to 4 mm ²		

- Strip I/O wires for 8 mm when using a screwless terminal block.

Note: The rated current for output terminals is 10 A per terminal.

Be sure to use multiple terminals simultaneously for current that exceeds the terminal rating.

When applying a current of 10 A or more, use at least two terminals each for the positive and negative wires.

Installation Environment

- Do not use the Power Supply in locations subject to shocks or vibrations. In particular, install the Power Supply as far away as possible from contactors or other devices that are a vibration source.
- Install the Power Supply well away from any sources of strong, high-frequency noise and surge.

Operating Life

- The life of a Power Supply is determined by the life of the electrolytic capacitors used inside. Here, Arrhenius Law applies, i.e., the life will be cut in half for each rise of 10°C or the life will be doubled for each drop of 10°C. The life of the Power Supply can thus be increased by reducing its internal temperature.

Ambient Operating and Storage Environments

- Store the Power Supply at a temperature of -40 to 85°C and a humidity of 0% to 95%.
- Do not use the Power Supply in areas outside the derating curve otherwise, internal parts may occasionally deteriorate or be damaged.
- Use the Power Supply at a humidity of 0% to 95%.
- Do not use the Power Supply in locations subject to direct sunlight.
- Do not use locations where liquids, foreign matter, or corrosive gases may enter the interior of Products.

Precautions for Correct Use

Mounting

- Take adequate measures to ensure proper heat dissipation to increase the long-term reliability of the Product. Be sure to allow convection in the atmosphere around devices when mounting. Do not use in locations where the ambient temperature exceeds the range of the derating curve.
- When cutting out holes for mounting, make sure that cuttings do not enter the interior of the Products.

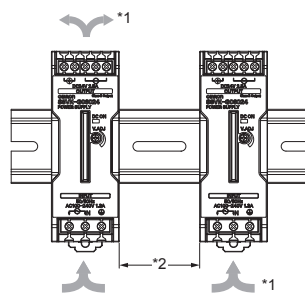

- *1. Convection of air
*2. 20 mm min.

- Improper mounting will interfere with heat dissipation and may occasionally result in deterioration or damage of internal parts. Use the Product within the derating curve for the mounting direction that is used.
- Use a mounting bracket when the Product is mounted facing horizontally.
- Heat dissipation will be adversely affected. When the Product is mounted facing horizontally, always place the side with the label facing upward.
- Operate the Power Supply within a range that is 5°C less than the values in the derating curve in *Engineering Data* on page 9 if the Power Supply is used with an installation spacing of 10 mm min. (20 mm max.) on the left and right.

Overcurrent Protection

- Internal parts may possibly deteriorate or be damaged if a short-circuited or overcurrent state continues during operation.
- Internal parts may possibly deteriorate or be damaged if the Power Supply is used for applications with frequent inrush current or overloading at the load end. Do not use the Power Supply for such applications.
- The DC ON indicator (green) flashes if the overload protection function operates.

Charging a Battery

If you connect a battery as the load, install overcurrent control and overvoltage protection circuits.

Output Voltage Adjuster (V.ADJ)

- The output voltage adjuster (V.ADJ) may possibly be damaged if it is turned with unnecessary force. Do not turn the adjuster with excessive force.
- After completing output voltage adjustment, be sure that the output capacity or output current does not exceed the rated output capacity or rated output current.

DIN Rail Mounting

To mount the Block on a DIN Rail, hook portion (A) of the Block onto the rail and press the Block in direction (B).

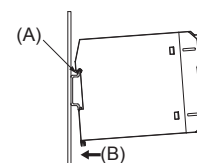

To dismount the Block, pull down portion (C) with a flat-blade screwdriver and pull out the Block.

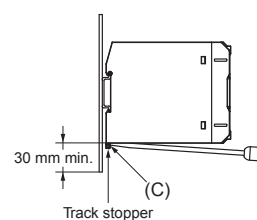

Series Operation

Two power supplies can be connected in series.

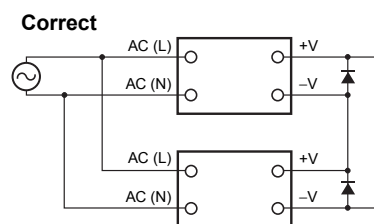

Note 1. The diode is connected as shown in the figure. If the load is short-circuited, a reverse voltage will be generated inside the Power Supply. If this occurs the Power Supply may possibly deteriorate or be damaged. Always connect a diode as shown in the figure. Select a diode having the following ratings.

Type	Schottky Barrier diode
Dielectric strength (V_{RRM})	Twice the rated output voltage or above
Forward current (I_F)	Twice the rated output current or above

2. Although Products having different specifications can be connected in series, the current flowing through the load must not exceed the smaller rated output current.

Making Positive/Negative Outputs

- The outputs are floating outputs (i.e., the primary circuits and secondary circuits are separated). You can therefore make positive and negative outputs by using two Power Supplies. You can make positive and negative outputs with any of the models.

If positive and negative outputs are used, connect Power Supplies of the same model as in the following figure. (Combinations with different output capacities or output voltages can be made. However, use the lower of the two maximum rated output currents as the current to the loads.)

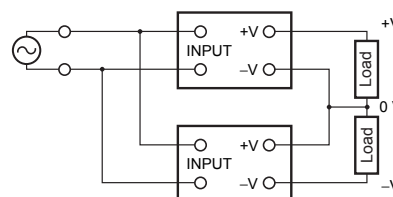

- Depending on the model, internal circuits may be damaged due to startup failure when the power is turned ON if loads such as a servomotor or operational amplifier may operate in series.

Therefore, connect bypass diodes (D1, D2) as shown in the following figure.

If the list of models that support series connection of outputs says that an external diode is not required, an external diode is also not required for positive/negative outputs.

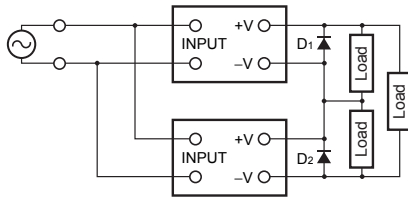

- Use the following information as a guide to the diode type, dielectric strength, and current.

- Type: Schottky barrier diode
- Dielectric strength (V_{RRM}): Twice the rated Power Supply output voltage or higher
- Forward current (I_F): Twice the rated Power Supply output current or higher

Backup Operation

Backup operation can be performed with S8VK-R.
Refer to the S8VK-R Datasheet for detail.

In Case There Is No Output Voltage

The possible cause for no output voltage may be that the overcurrent or overvoltage protection has operated. The internal protection may operate if a large amount of surge voltage such as a lightning surge occurs while turning ON the power supply.

In case there is no output voltage, please check the following points before contacting us:

- Checking overload protected status:
 - Check whether the load is in overload status or is short-circuited.
 - Remove wires to load when checking.
- Checking overvoltage or internal protection:
 - Turn the power supply OFF once, and leave it OFF for at least 3 minutes. Then turn it ON again to see if this clears the condition.

Audible Noise at Power ON

(120-W, 180-W, 240-W, and 480-W Models)

A harmonic current suppression circuit is built into the Power Supply. This circuit can create noise when the input is turned ON, but it will last only until the internal circuits stabilize and does not indicate any problem in the Product.

Terms and Conditions of Sale

1. **Offer; Acceptance.** These terms and conditions (these "**Terms**") are deemed part of all quotes, agreements, purchase orders, acknowledgments, price lists, catalogs, manuals, brochures and other documents, whether electronic or in writing, relating to the sale of products or services (collectively, the "**Products**") by Omron Electronics LLC and its subsidiary companies ("**Omron**"). Omron objects to any terms or conditions proposed in Buyer's purchase order or other documents which are inconsistent with, or in addition to, these Terms.
2. **Prices; Payment Terms.** All prices stated are current, subject to change without notice by Omron. Omron reserves the right to increase or decrease prices on any unshipped portions of outstanding orders. Payments for Products are due net 30 days unless otherwise stated in the invoice.
3. **Discounts.** Cash discounts, if any, will apply only on the net amount of invoices sent to Buyer after deducting transportation charges, taxes and duties, and will be allowed only if (i) the invoice is paid according to Omron's payment terms and (ii) Buyer has no past due amounts.
4. **Interest.** Omron, at its option, may charge Buyer 1-1/2% interest per month or the maximum legal rate, whichever is less, on any balance not paid within the stated terms.
5. **Orders.** Omron will accept no order less than \$200 net billing.
6. **Governmental Approvals.** Buyer shall be responsible for, and shall bear all costs involved in, obtaining any government approvals required for the importation or sale of the Products.
7. **Taxes.** All taxes, duties and other governmental charges (other than general real property and income taxes), including any interest or penalties thereon, imposed directly or indirectly on Omron or required to be collected directly or indirectly by Omron for the manufacture, production, sale, delivery, importation, consumption or use of the Products sold hereunder (including customs duties and sales, excise, use, turnover and license taxes) shall be charged to and remitted by Buyer to Omron.
8. **Financial.** If the financial position of Buyer at any time becomes unsatisfactory to Omron, Omron reserves the right to stop shipments or require satisfactory security or payment in advance. If Buyer fails to make payment or otherwise comply with these Terms or any related agreement, Omron may (without liability and in addition to other remedies) cancel any unshipped portion of Products sold hereunder and stop any Products in transit until Buyer pays all amounts, including amounts payable hereunder, whether or not then due, which are owing to it by Buyer. Buyer shall in any event remain liable for all unpaid accounts.
9. **Cancellation; Etc.** Orders are not subject to rescheduling or cancellation unless Buyer indemnifies Omron against all related costs or expenses.
10. **Force Majeure.** Omron shall not be liable for any delay or failure in delivery resulting from causes beyond its control, including earthquakes, fires, floods, strikes or other labor disputes, shortage of labor or materials, accidents to machinery, acts of sabotage, riots, delay in or lack of transportation or the requirements of any government authority.
11. **Shipping; Delivery.** Unless otherwise expressly agreed in writing by Omron:
 - a. Shipments shall be by a carrier selected by Omron; Omron will not drop ship except in "break down" situations.
 - b. Such carrier shall act as the agent of Buyer and delivery to such carrier shall constitute delivery to Buyer;
 - c. All sales and shipments of Products shall be FOB shipping point (unless otherwise stated in writing by Omron), at which point title and risk of loss shall pass from Omron to Buyer; provided that Omron shall retain a security interest in the Products until the full purchase price is paid;
 - d. Delivery and shipping dates are estimates only; and
 - e. Omron will package Products as it deems proper for protection against normal handling and extra charges apply to special conditions.
12. **Claims.** Any claim by Buyer against Omron for shortage or damage to the Products occurring before delivery to the carrier must be presented in writing to Omron within 30 days of receipt of shipment and include the original transportation bill signed by the carrier noting that the carrier received the Products from Omron in the condition claimed.
13. **Warranties.** (a) **Exclusive Warranty.** Omron's exclusive warranty is that the Products will be free from defects in materials and workmanship for a period of twelve months from the date of sale by Omron (or such other period expressed in writing by Omron). Omron disclaims all other warranties, express or implied. (b) **Limitations.** OMRON MAKES NO WARRANTY OR REPRESENTATION, EXPRESS OR IMPLIED, ABOUT NON-INFRINGEMENT, MERCHANTABILITY OR FITNESS FOR A PARTICULAR PURPOSE OF THE PRODUCTS. BUYER ACKNOWLEDGES THAT IT ALONE HAS DETERMINED THAT THE PRODUCTS WILL SUITABLY MEET THE REQUIREMENTS OF THEIR INTENDED USE. Omron further disclaims all warranties and responsibility of any type for claims or expenses based on infringement by the Products or otherwise of any intellectual property right. (c) **Buyer Remedy.** Omron's sole obligation hereunder shall be, at Omron's election, to (i) replace (in the form originally shipped with Buyer responsible for labor charges for removal or replacement thereof) the non-complying Product, (ii) repair the non-complying Product, or (iii) repay or credit Buyer an amount equal to the purchase price of the non-complying Product; provided that in no event shall Omron be responsible for warranty, repair, indemnity or any other claims or expenses regarding the Products unless Omron's analysis confirms that the Products were properly handled, stored, installed and maintained and not subject to contamination, abuse, misuse or inappropriate modification. Return of any Products by Buyer must be approved in writing by Omron before shipment. Omron Companies shall not be liable for the suitability or unsuitability or the results from the use of Products in combination with any electrical or electronic components, circuits, system assemblies or any other materials or substances or environments. Any advice, recommendations or information given orally or in writing, are not to be construed as an amendment or addition to the above warranty. See <http://www.omron247.com> or contact your Omron representative for published information.
14. **Limitation on Liability; Etc.** OMRON COMPANIES SHALL NOT BE LIABLE FOR SPECIAL, INDIRECT, INCIDENTAL, OR CONSEQUENTIAL DAMAGES, LOSS OF PROFITS OR PRODUCTION OR COMMERCIAL LOSS IN ANY WAY CONNECTED WITH THE PRODUCTS, WHETHER SUCH CLAIM IS BASED IN CONTRACT, WARRANTY, NEGLIGENCE OR STRICT LIABILITY. Further, in no event shall liability of Omron Companies exceed the individual price of the Product on which liability is asserted.
15. **Indemnities.** Buyer shall indemnify and hold harmless Omron Companies and their employees from and against all liabilities, losses, claims, costs and expenses (including attorney's fees and expenses) related to any claim, investigation, litigation or proceeding (whether or not Omron is a party) which arises or is alleged to arise from Buyer's acts or omissions under these Terms or in any way with respect to the Products. Without limiting the foregoing, Buyer (at its own expense) shall indemnify and hold harmless Omron and defend or settle any action brought against such Companies to the extent based on a claim that any Product made to Buyer specifications infringed intellectual property rights of another party.
16. **Property; Confidentiality.** Any intellectual property in the Products is the exclusive property of Omron Companies and Buyer shall not attempt to duplicate it in any way without the written permission of Omron. Notwithstanding any charges to Buyer for engineering or tooling, all engineering and tooling shall remain the exclusive property of Omron. All information and materials supplied by Omron to Buyer relating to the Products are confidential and proprietary, and Buyer shall limit distribution thereof to its trusted employees and strictly prevent disclosure to any third party.
17. **Export Controls.** Buyer shall comply with all applicable laws, regulations and licenses regarding (i) export of products or information; (ii) sale of products to "forbidden" or other proscribed persons; and (iii) disclosure to non-citizens of regulated technology or information.
18. **Miscellaneous.** (a) **Waiver.** No failure or delay by Omron in exercising any right and no course of dealing between Buyer and Omron shall operate as a waiver of rights by Omron. (b) **Assignment.** Buyer may not assign its rights hereunder without Omron's written consent. (c) **Law.** These Terms are governed by the law of the jurisdiction of the home office of the Omron company from which Buyer is purchasing the Products (without regard to conflict of law principles). (d) **Amendment.** These Terms constitute the entire agreement between Buyer and Omron relating to the Products, and no provision may be changed or waived unless in writing signed by the parties. (e) **Severability.** If any provision hereof is rendered ineffective or invalid, such provision shall not invalidate any other provision. (f) **Setoff.** Buyer shall have no right to set off any amounts against the amount owing in respect of this invoice. (g) **Definitions.** As used herein, "including" means "including without limitation"; and "Omron Companies" (or similar words) mean Omron Corporation and any direct or indirect subsidiary or affiliate thereof.

Certain Precautions on Specifications and Use

1. **Suitability of Use.** Omron Companies shall not be responsible for conformity with any standards, codes or regulations which apply to the combination of the Product in the Buyer's application or use of the Product. At Buyer's request, Omron will provide applicable third party certification documents identifying ratings and limitations of use which apply to the Product. This information by itself is not sufficient for a complete determination of the suitability of the Product in combination with the end product, machine, system, or other application or use. Buyer shall be solely responsible for determining appropriateness of the particular Product with respect to Buyer's application, product or system. Buyer shall take application responsibility in all cases but the following is a non-exhaustive list of applications for which particular attention must be given: (i) Outdoor use, uses involving potential chemical contamination or electrical interference, or conditions or uses not described in this document. (ii) Use in consumer products or any use in significant quantities. (iii) Energy control systems, combustion systems, railroad systems, aviation systems, medical equipment, amusement machines, vehicles, safety equipment, and installations subject to separate industry or government regulations. (iv) Systems, machines and equipment that could present a risk to life or property. Please know and observe all prohibitions of use applicable to this Product. NEVER USE THE PRODUCT FOR AN APPLICATION INVOLVING SERIOUS RISK TO LIFE OR PROPERTY OR IN LARGE QUANTITIES WITHOUT ENSURING THAT THE SYSTEM AS A WHOLE HAS BEEN DESIGNED TO ADDRESS THE RISKS, AND THAT THE OMRON'S PRODUCT IS PROPERLY RATED AND INSTALLED FOR THE INTENDED USE WITHIN THE OVERALL EQUIPMENT OR SYSTEM.
2. **Programmable Products.** Omron Companies shall not be responsible for the user's programming of a programmable Product, or any consequence thereof.
3. **Performance Data.** Data presented in Omron Company websites, catalogs and other materials is provided as a guide for the user in determining suitability and does not constitute a warranty. It may represent the result of Omron's test conditions, and the user must correlate it to actual application requirements. Actual performance is subject to the Omron's Warranty and Limitations of Liability.
4. **Change in Specifications.** Product specifications and accessories may be changed at any time based on improvements and other reasons. It is our practice to change part numbers when published ratings or features are changed, or when significant construction changes are made. However, some specifications of the Product may be changed without any notice. When in doubt, special part numbers may be assigned to fix or establish key specifications for your application. Please consult with your Omron's representative at any time to confirm actual specifications of purchased Product.
5. **Errors and Omissions.** Information presented by Omron Companies has been checked and is believed to be accurate; however, no responsibility is assumed for clerical, typographical or proofreading errors or omissions.

OMRON INDUSTRIAL AUTOMATION • THE AMERICAS HEADQUARTERS

Schaumburg, IL USA • 847.843.7900 • 800.556.6766 • www.omron247.com

OMRON CANADA, INC. • HEAD OFFICE

Toronto, ON, Canada • 416.286.6465 • 866.986.6766 • www.omron247.com

OMRON ELECTRONICS DE MEXICO • HEAD OFFICE

México DF • 52.55.59.01.43.00 • 001.800.556.6766 • mela@omron.com

OMRON ELECTRONICS DE MEXICO • SALES OFFICE

Apodaca, N.L. • 52.81.11.56.99.20 • 001.800.556.6766 • mela@omron.com

OMRON ELETRÔNICA DO BRASIL LTDA • HEAD OFFICE

São Paulo, SP, Brasil • 55.11.2101.6300 • www.omron.com.br

OMRON ARGENTINA • SALES OFFICE

Cono Sur • 54.11.4783.5300

OMRON CHILE • SALES OFFICE

Santiago • 56.9.9917.3920

OTHER OMRON LATIN AMERICA SALES

54.11.4783.5300

OMRON EUROPE B.V. • Wegalaan 67-69, NL-2132 JD, Hoofddorp, The Netherlands. • Tel: +31 (0) 23 568 13 00

Fax: +31 (0) 23 568 13 88 • www.industrial.omron.eu